

The FOLLOWING INFORMATION HAS BEEN SUPPLIED AS A SERVICE AND ON THE BASIS THAT THE Traveler Responsibilities and Obligations (below), APPLY:

- All travelers are solely responsible for ensuring that they are in the possession of and have complied with: (1) the correct travel documentation, including passports valid for the minimum period after the tour, required by law in each country the traveler will visit; (2) the correct visas/re-entry permits, valid for the countries visited – the visa costs incurred are for the traveler's own account.
- All travelers are solely responsible for any consequences whatsoever should the traveler fail to ensure that he/she has complied with the necessary health, passport, visa, re-entry permits, or other legal requirements.
- All travelers are solely responsible for taking out comprehensive travel insurance and to familiarize themselves with any exceptions and conditions as may be imposed by the insurer.

*Please remember to check accuracy of information recorded in your digital itinerary.
Please ensure you have ALL your travel documents at hand for crossing a border.*

TRAVEL ADVISORIES for United States Passport Holders

DESTINATIONS: BOTSWANA | NAMIBIA | SOUTH AFRICA | ZAMBIA | ZIMBABWE

General information about your destination country/ies is contained on the **INFORMATION** tab on your digital itinerary

INDEX

IF CONTENTS UPDATED, DOCUMENT WILL BE REDATED AND NEW INFORMATION WILL BE IN GREEN

Page 2	VISAS & PASSPORTS
Page 3	ELECTRONIC TRAVEL AUTHORIZATION (ETA)
Page 4	BORDER PROCEDURES
Page 5	CUSTOMS
Page 6	HEALTH REQUIREMENTS & MEDICATIONS
Page 7	BANKING AND CURRENCY GENERAL TIPPING INFORMATION
Page 8	PACKING CHECKLIST ELECTRICAL DEVICES
Page 9	LUGGAGE RESTRICTIONS – INTERNAL/LOCAL/DOMESTIC
Page 10	LUGGAGE RESTRICTIONS – INTERCAMP BUSH FLIGHTS
Page 11	TRANSPORT SCHEDULE & TOUR ITINERARY
Page 12	PRINTABLE ITINERARY MOBILE APP FOR YOUR ITINERARY CELLULAR PHONES & WIFI
Page 13	TOUR VEHICLE GAME VEHICLE LAUNDRY IMPORTANT CURRENT NEWS FUN STUFF

CLOSER TO TRAVEL WE WILL UPLOAD INTO DOCUMENTS TAB:

- TOUR-SPECIFIC-TIPPING-GUIDELINE CHART
- WEATHER FORECAST

WHATSAPP CONTACT

Before departure, you will be added to a WhatsApp Group that gives you access to guides, operations & logistics management. At that time, we suggest you also save those contacts to your phone.

VISAS & PASSPORTS

Please note entry requirements can change without notice; please check with the US State Department

For USA Travel Updates: <https://travel.state.gov/content/travel/en/international-travel.html>

Citizens of the United States of America require a valid passport to enter **Botswana, Namibia, South Africa, Zambia** and **Zimbabwe**. Traveler must hold proof of an onward ticket. Please note that immigration officers hold the right to deny entry to any traveler. If traveling with children under the age of 18, please contact the consulate for all details prior to travel. **“Blank page/s” mentioned below means free of any other stamps on those VISA-marked pages in your passport.**

BOTSWANA

<https://travel.state.gov/content/travel/en/international-travel/International-Travel-Country-Information-Pages/Botswana.html>

U.S. passport holders do not need a visa to visit Botswana for up to 90 days within a 12-month period. However, Botswana immigration officials will record the total stay permitted for each visit on the entry stamp, which may be less than 90 days. You must have a passport that has 3 blank pages *per entry*. The passport must be valid for more than six months after the intended return date to your home country.

NAMIBIA

<https://travel.state.gov/content/travel/en/international-travel/International-Travel-Country-Information-Pages/Namibia.html>

U.S. passport holders visiting Namibia for tourism need a holiday visa which is valid for up to 3 months. Pre-tour application and payment are available via E-services (<https://eservices.mhaiss.gov.na/holidayvisa-services>) on Namibia's Ministry of Home Affairs, Immigration, Safety and Security website. Alternatively, pay on arrival by credit card (MasterCard or Visa only) You must have a passport that has 3 blank pages *per entry*. The passport must be valid for more than six months after the intended return date to your home country.

SOUTH AFRICA

<https://travel.state.gov/content/travel/en/international-travel/International-Travel-Country-Information-Pages/SouthAfrica.html>

U.S. passport holders do not need an advance visa unless travel is for more than 90-days. You must have a passport that has 2 consecutive blank pages *per entry*. The passport must be valid for more than 30 days after the intended return date to your home country.

ZAMBIA

<https://travel.state.gov/content/travel/en/international-travel/International-Travel-Country-Information-Pages/Zambia.html>

U.S. citizens do not need a visa to visit Zambia for up to 30 days for business or 90 days for tourism within a one-year period. You must have a passport that has 3 blank pages *per entry*. The passport must be valid for more than six months after the intended return date to your home country.

ZIMBABWE

<https://travel.state.gov/content/travel/en/international-travel/International-Travel-Country-Information-Pages/Zimbabwe.html>

U.S. passport holders need a visa for entry into Zimbabwe, and they are issued on arrival (VoA) at your point of entry. Have cash on you to pay. You must have a passport that has at least 2 blank pages *per entry*. The passport must be valid for more than six months after the intended return date to your home country.

The KAZA UNIVISA costs USD \$50 (recommend cash) and is valid for 30 days for multiple entries between Zambia and Zimbabwe and allows day trips to Botswana through the Kazungula Border. It does not include overnight stays in Botswana.

ELECTRONIC TRAVEL AUTHORIZATION

SOUTH AFRICA

Contact South African Embassy for up-to-date information: <https://www.saembassy.org>

Contact Department of Homeland Affairs for up-to-date information: <https://www.dha.gov.za/>

Clients from visa-exempt countries (USA is currently a visa-exempt country) continue entering with just their passports, though optional biometric capture is being explored for these travelers in future.

Who does ETA apply to?

The ETA is only for tourists from **visa-requiring countries**. They will be required to obtain an Electronic Travel Authorization (ETA) for entry into South Africa. It is recommended travelers apply for their ETA well in advance of their planned travel date.

1. Apply for the ETA:

You apply for an ETA through the official platform, which will require uploading a photograph of your passport, a photo of yourself, your flight itinerary, and other personal information.

2. Submit Information Online:

The application process will be online, involving secure payment and confirmation.

3. Receive Digital Code:

You will receive a unique digital code linked to your passport after approval. Please print it out and keep it in your passport.

4. Arrive and Scan:

Upon arrival in South Africa, you will be required to scan your ETA code at a port of entry.

5. Biometric Verification:

Your biometric data will then be checked against your passport and the details provided during the ETA application.

ZIMBABWE

All passengers entering Zimbabwe, should complete the Zimbabwe Arrivals Declaration online at <https://www.evisa.gov.zw/app/index.html#/standby-kiosk> before arrival. While you can complete it upon arrival via the airport kiosks, doing so in advance is strongly recommended to avoid potential delays.

BORDER PROCEDURES

BOTSWANA

To combat the spread of Foot and Mouth Disease (FMD), Botswana borders near Chobe have a strict quarantine process for all travelers. This involves comprehensive disinfection of vehicles and footwear, and a ban on bringing in most meat and fresh animal products. These measures are in place because the Chobe region borders wildlife areas where buffalo, a common carrier of FMD, roam freely. The border is not the only place with FMD checkpoints. The government maintains a network of veterinary cordon fences and checkpoints within the country. If you are traveling through the Chobe region and on toward the south of Botswana, you can expect to encounter further checkpoints where you must repeat the disinfection process.

Vehicle disinfection

- When driving across the border, your vehicle is required to pass through a shallow trough filled with a disinfectant solution.
- The purpose is to sanitize your vehicle's tires, removing any viruses or contaminants from the road.

Footwear disinfection

- All passengers must step out of the vehicle and walk across a damp mat or trough that contains a disinfectant solution.
- In addition to the shoes being worn, travelers may be required to place any other shoes they are carrying onto the mat for treatment.

CUSTOMS

SOUTH AFRICA

NEW South African Revenue Service (SARS) System <https://www.sars.gov.za/travellerdeclaration/>

This system provides the option for travelers leaving or entering South Africa by air to complete and submit an online traveler declaration and receive electronic confirmation thereof *before* they travel. It is not required before travel and can be done upon arrival.

DECLARING ELECTRONIC EQUIPMENT IN SOUTH AFRICA (Form TC01)

Travelers arriving in South Africa are advised to declare their electronic equipment, including cameras and laptops, even if they intend to take these items back with them upon their departure from South Africa. Although customs officials may not always enforce this rule for travelers with standard personal electronics, it is best practice to comply, avoiding potential hassles and delays. There is currently no specific value threshold for declaring electronic equipment.

Declaration Process

- Online Traveler Declaration System: <https://www.sars.gov.za/travellerdeclaration/>
- Manual Declaration: Complete the physical Traveler Card (TC01 form) upon arrival at customs
- On returning home: When departing South Africa, travelers are not required to declare the same equipment again if this was declared upon arrival and proof (online confirmation or stamped TC01 form) has been retained.

REFUNDABLE CASH DEPOSITS OR IMPORT DUTIES ON GOODS

Be aware you may need to pay refundable cash deposits or import duties on certain goods brought into South Africa temporarily. Refunds are provided once the goods are shown to have left the country. You can access the **SARS Traveller Leaflet** on the SARS website which provides essential information on prohibited items, restrictions, duty-free allowances, and other pertinent customs details.

NAMIBIA

CURRENCY RESTRICTIONS FOR ENTRY & EXIT:

Amounts over NAD 100,000 or its equivalent in any foreign currency must be declared

HEALTH REQUIREMENTS & MEDICATIONS

COVID-19

CDC: <https://www.cdc.gov/coronavirus/2019-ncov/travelers/testing-international-air-travelers.html>

It is advisable to carry any Covid records you have albeit regulations are lifted.

There are no COVID-19 testing or vaccination requirements for travelers to Botswana, South Africa, Namibia and Zambia.

VACCINATIONS & INNOCULATIONS

Please check on the Centers for Disease Control and Prevention (CDC) website <https://www.cdc.gov/> and with your local health clinic. And consult with your doctor.

YELLOW FEVER

There are **currently** no yellow fever vaccination requirements for entering Botswana, South Africa, Namibia and Zambia from non-endemic yellow fever countries.

MALARIA

Please refer table from the CDC: https://www.cdc.gov/malaria/travelers/country_table/b.html

Please consult your medical practitioner on anti-malaria prophylactics. We recommend the malaria tablet while in malaria areas, however, it is not mandatory.

MEDICATIONS

You should bring medications, sufficient for the duration of your trip, in the original packaging. This is for prescribed and over-the-counter medications. Carry your prescriptions. And bring over-the counter medications you know you need, for example, if you know you suffer from motion sickness – Dramamine.

SPECIAL MENTION: CONTROLLED AND PROHIBITIVE SUBSTANCES

Medications containing diphenhydramine, such as Benadryl, are illegal in **Zambia**.

BANKING AND CURRENCY

Refer the **INFORMATION** tab on your digital itinerary

Cash for personal use

USD\$50 cash will be **more** than sufficient to have on your person at the commencement of your tour.

If you wish, you can purchase local currency at the airport on arrival (just ask your guide).

As the tour progresses and as needed, inform your guide timeously and he will arrange for you to draw cash from an ATM or from a bank (local currency).

*Tiping in Africa is either in the local currency of your destination
OR in US Dollars which are accepted in most instances.*

Cash for tipping

You can choose to bring the total in USD cash with you or withdraw local currency as you complete each leg. Some guides carry portable CC devices – just enquire.

During the tour you may wish to tip for something not listed (for example street entertainers) so you will want to make sure you have sufficient low denomination USDs on hand (\$1's & \$5's) or local currency.

FYI ~ SOUTH AFRICA: According to the current South African Exchange Control laws, travellers cannot draw any other currency than the local currency. The only way to get USDs in South Africa is if you are a South African Resident in possession of an International Flight Ticket, a valid South African Passport, and Proof of Residence in South Africa. Travellers will need to bring USDs with them; more than USD10,000 must be declared on entry to the country.

GENERAL TIPPING INFORMATION

It is customary and appreciated to tip service industry staff but it is always at your discretion and depending on the level of service you receive. We support travel service professionals in their efforts to determine their tipping income in keeping with their commitment to and delivery of excellence. Also, we support the payment of these tips **direct to these professionals** with no interference from us. Guests very often comment that they prefer and enjoy handing over the gratuities personally.

Closer to travel we provide a **TOUR-SPECIFIC-TIPPING-GUIDELINE CHART**

Please remember:

Gratuities for restaurant staff have been paid on most meals included in your tour itinerary.

Where the gratuities are not included, it will be listed on the Chart.

Area Tour Guides:

Tipping takes place at the end of an area's leg for that Area Guide.

Game Lodge Guides:

You may not always have a tracker/spotter and you may not have the same game staff for each game drive.

Tipping takes place at the end of your lodge visit and can be left with reception, marked appropriately in envelopes they provide.

For your account:

Where meals and drinks are for your account, the gratuities are also for your account.

Restaurant and bar wait staff: 10% - 15% is commonplace - more for special service.

PACKING CHECKLIST

People often ask what they should pack when traveling to Southern Africa. Through our own and previous guest experiences, we have compiled a list of those items found to be most useful and necessary:

- ✓ 1-2 Pairs of smart-casual trousers
- ✓ 2-3 Pairs of shorts
- ✓ 4 Shirts and/or T-shirts (any combination)
- ✓ Light cotton sundress for the ladies
- ✓ Walking/hiking/running shoes (must be a closed shoe for the bushveld)
- ✓ Sandals, crocks, or similar (do NOT wear in the bushveld)
- ✓ Swimsuit
- ✓ Sunhat
- ✓ Sunscreen
- ✓ Water bottle
- ✓ Mosquito repellent
- ✓ Good binoculars
- ✓ Light jacket / cardigan for the evenings (depending on the season)

Notes on safari-specific clothing and items:

- Morning and evening safaris can be very cold, even in summer. Pack a warm fleece jacket, scarf and gloves.
- Keep clothing colors neutral to blend with the environment. Khaki, browns and greens work well. Dark and bright colors tend to attract insects.
- Meals on safari are generally informal, so it is not necessary to dress up for dinner.
- Summer months are December through March, which is also the rainy season. You may experience light drizzle or rainstorms, but storms only last for about an hour. Game lodges provide umbrellas and then rain ponchos during game drives. In winter, which is from June through September, fleece blankets are provided during game drives.

General Notes:

- You may want to bring extra memory cards if using a video or digital camera.
- If using your cell phone during game drives and bushwalks, please make sure it is silent mode so as not to disturb the animals.
- We suggest you bring a spare pair of prescription eyeglasses or contact lenses in case yours are lost or damaged, and plenty of lens cleaning solution.
- All rooms are supplied with basic amenities such as soap and shampoo. You may, however, wish to bring your own favorite items.
- Please travel with minimal luggage. We suggest using only ONE suitcase, if possible, as domestic airlines baggage weight restrictions are greater than on international flights.
- Please note that not all curios purchased in South Africa may be imported to your country of origin. For example, wood, animal products, shells, etc. often need clearance documentation.

ELECTRICAL DEVICES

Refer the **INFORMATION** tab on your digital itinerary for voltage info and adapter/converter requirements.

Electricity in South Africa works on a 220-volt alternating current system. Wall plug units take a round pin 15 Amp plug. Bring a converter or adapter to charge devices and use appliances.

LUGGAGE RESTRICTIONS – INTERNAL/LOCAL/DOMESTIC

SCHEDULED COMMERCIAL FLIGHTS

The following luggage restrictions are based on the most stringent restrictions across these 3 airlines:

AIRLINK, CEMAIR & FASTJET for Economy Class per adult passenger

(Imperial System weights/measurements are in purple)

CHECKED LUGGAGE

One piece - 20 kg max (44lbs max)

(H) 90cm (2ft 11in) + (W) 72cm (2ft 4in) + (L) 45cm (1ft 6in) (including handle, wheels and pockets) total dimensions 207cm (81.5in)

CARRY-ON LUGGAGE

One piece – slim line laptop bag OR one small handbag/personal bag

(H) 40cm (1ft 4in) + (W) 30cm (1ft) + (L) 15cm (6in)

One piece - 7kg max (15.4lbs max)

(H) 55cm (1ft 10in) + (W) 35 cm (1ft 2in) + (L) 20cm (8in) (including handle, wheels and pockets) total dimensions 115cm (45.30in)

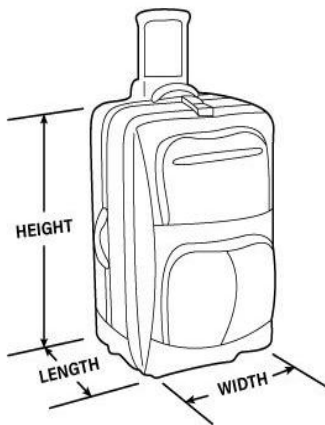

INTERCAMP BUSH SHUTTLE FLIGHTS

The luggage restrictions for the smaller aircraft which operate intercamp bush shuttle flights, are considerably stricter due to smaller luggage compartments.

Only soft-shell luggage is permitted.

COMBINED CHECKED AND CARRY-ON LUGGAGE WEIGHT

20 kg max (44lbs max)

CHECKED LUGGAGE DIMENSIONS

(H) 42cm (16.5in) + (W) 30cm (12 in) + (L) 70cm (28 in) (including handle, wheels and pockets) total dimensions 142cm (56.5in)

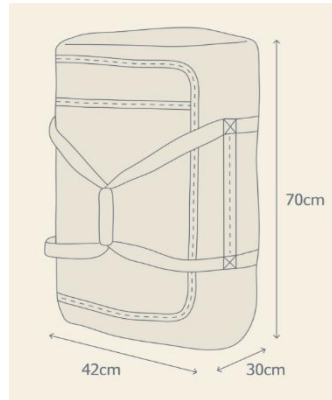

Should your luggage exceed the limits of bush aircraft, a service is available to arrange for it to seamlessly travel unaccompanied and safely to the next destination after your bush flights, ensuring your journey remains effortless.

When available, your e-tickets will be added to the **DOCUMENTS** tab.

TRANSPORT SCHEDULE & TOUR ITINERARY

It is important that you monitor your international flights for any changes prior to your departure and directly with your airline

Please check your **TRANSPORT** tab in your digital itinerary. All airport transfers and point-to-point transfers will be itemized under that tab.

(It is important to note that if you are scheduled for transfers from the airport, you should not use Taxi/Uber transportation. If you do, we cannot be held responsible for the liability of their financial cost or dependability).

Sequence and times of daily excursions and transfers as detailed in your itinerary may vary depending upon weather and other factors. Your guide can assist if you have any questions in this regard.

PRINTABLE ITINERARY

When available, a printable version (PDF file) of your digital itinerary will be added to the **DOCUMENTS** tab. We will also add a word (DOCX file) should you wish to edit down the file before printing. It is recommended you only print a day before departure, so you have the latest updates.

MOBILE APP FOR YOUR ITINERARY

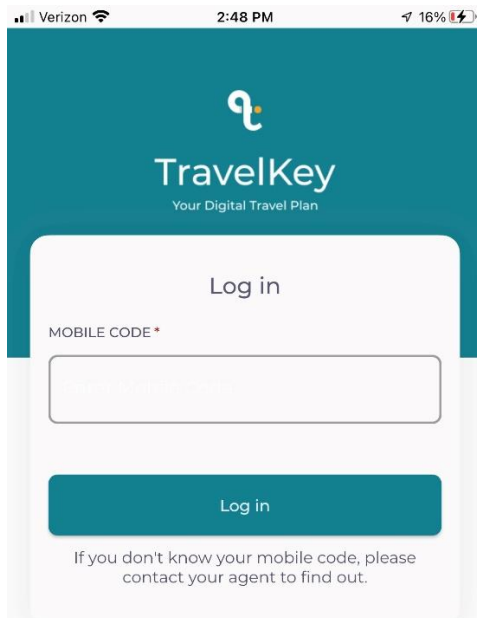

- Go to your mobile phone App store and search for the "TravelKey" App, exclusive to Wetu users, and download (it is free)
- Your Mobile Code will be provided on the **INTRODUCTION** tab of your personal itinerary
- To see itinerary updates, click on the "hamburger" at bottom RHS of screen
- Tap "Refresh Itinerary" near the bottom of that screen – do that each morning, at least, and when connected to the internet
- Information, last refreshed, will remain in the app when you don't have access to the internet

CELLULAR PHONES & WIFI

We suggest that you arrange roaming for your personal cellular phone prior to departing. This is for emergencies only and will generally not incur additional charges except if you receive or make calls, or send text messages. Confirm the charges and details with your carrier prior to departure. Doing this will allow you to contact our operational team in South Africa from your arrival and in case of an emergency. Wi-Fi is available at all lodging on your tour but internet speed, compared with internet speed in the USA, is significantly slower. You might therefore find downloading and uploading of information such as photos and e-mails to be significantly slower than what you normally experience. We do not suggest using data on your personal phone while roaming. If you intend to do so, we recommend you contact your carrier regarding pricing prior to departure. **Please be aware connection to the internet is not always reliable in Africa.**

TOUR VEHICLE

Your tour vehicle will be on your digital itinerary along with information about drivers and guides. Outsourced straight transfers and specialty excursions may be in a different size vehicle and may include other guests.

GAME VEHICLE



A game viewing vehicle or safari vehicle is an off-road vehicle that is converted or modified to carry 9 people on 3 raked rows from which they can view game. These vehicles are usually open and do not have roofs, the reason for this is to improve visibility. You may have people from outside your group on game drives.

One of the main things the ranger will discuss in the opening briefing is the issue of standing up in the vehicle and how this will affect the animals. The animals are wild and as such they still have the inherent fear of humans - and standing up in the safari vehicle will break the profile of the vehicle that the animals have become used to. This will ensure that the animal runs away or becomes aggressive. The ranger is usually assisted by a tracker who sits up front on the vehicle and relays information to the guide from what he reads in the signs of the wilderness around him. The trackers are mostly people who have grown up in the area and know the bush and its intricacies intimately.

LAUNDRY

It is advisable to process laundry at hotels/lodges where you stay for at least 2 nights.

IMPORTANT CURRENT NEWS

ELECTRICITY

South Africa may be experiencing load shedding stages during your tour (with stage 1 being the least serious, and stage 8 being the most serious). The energy crisis comes and goes (cyclical). You may experience interruption of electricity/power. Lodges/hotels do have generators.

FUN STUFF

Some Words and Expressions that will go a long way and get you extra service with a smile:

Ja Asseblief = Yes Please

Nee Dankie = No Thank You

Baie Dankie - sounds like "buy a donkey" = Thank You Very Much

Howzit = How are you doing?

Totsiens = Goodbye

Hamba Kahle = Travel Well